

**VACALL™**

**Sweeper  
Cleaner**



**Dynamic Multi-Purpose  
Vacuum Street Sweeper**

.....In a Performance Class by Itself

Powerful street maintenance solutions can handle more work...

# everyday



Versatile Vacall street sweeper models set the industry standard for high value, high return on equipment budgets thanks to their greater vacuum forces, raw strength and wider range of versatility options. All day, every day, Vacall street sweeper models can work the entire street delivering superior benefits for municipalities and private contractors that strive to do more work with fewer machines.



Vacall brand street sweepers feature unique advantages to make short work of routine or even intense cleanup jobs on residential streets, busy highways, parking areas and special event venues.

Extra vacuum power is at the heart of the job-proven Vacall model designs. Single or dual sweep cleanup models have vacuum nozzles, transfer brooms and gutter brooms

on one or both sides of the chassis to quickly remove sand, gravel, wet or dry leaves, discarded bottles and cans – even asphalt millings from re-surfacing projects.

To expand the versatility of your Vacall machine, choose the rugged catch basin cleanout system from the list of options. Mounted at the rear of the chassis, this assembly extends the machine's capabilities by vacuuming leaves and debris from storm sewers and catch basins – once again building greater return into your equipment investment.

## **Sweeper Cleaner**

**Dynamic Multi-Purpose Vacuum Street Sweeper**

# ay.

## ► Rugged Debris Bodies.

Fabricated with reinforced, heavy grade steel, debris bodies are available with capacities of 10, 13 and 16 cubic yards.



## ► Single or Dual Gutter Brooms

Mounted on one or both sides of the chassis, these 30-inch brooms are built to last with flat tempered double steel wire. Raising, lowering and variable speeds are controlled in the chassis cab.

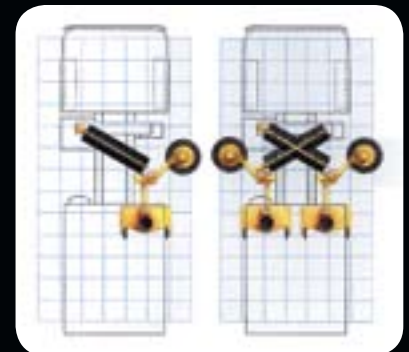

Curbside vacuum nozzle, gutter broom and fixed transfer broom

Dual vacuum nozzles, gutter brooms and swivel transfer broom

## ► Under Body Transfer Brooms

Rugged polypropylene disposable brooms build cleaning efficiency by directing debris to gutter brooms. Transfer brooms are in a fixed position on single-broom units, or swivel with dual sweep options.



## ► High Capacity Water System

For longer cleaning runs, high capacity water pumps draw from a storage tank with up to 420 gallons of capacity. Controls are located both in the cab and on the side of the chassis.



## ► Optional Catch Basin Cleanout Assembly

A front-mounted assembly with vacuum hose and variable length aluminum or steel tubes expands the versatility of the street sweeper. Using pendant controls, the assembly quickly clears debris from catch basins or even collects leaves.



## ► Efficient Debris Dump System

A strong, double-acting hydraulic cylinder raises and lowers the debris body which is equipped with a full-opening tailgate door completing the industry's best easy-dump design.

## ► Large Vacuum Pickup Nozzles

High power vacuum nozzles are available from 42 to 48 inches wide, creating up to 450 square inches of coverage. Able to accommodate larger debris, nozzles also are able to clean faster and with greater efficiency with the industry's greatest vacuum forces created with a 16,500 CFM centrifugal fan.

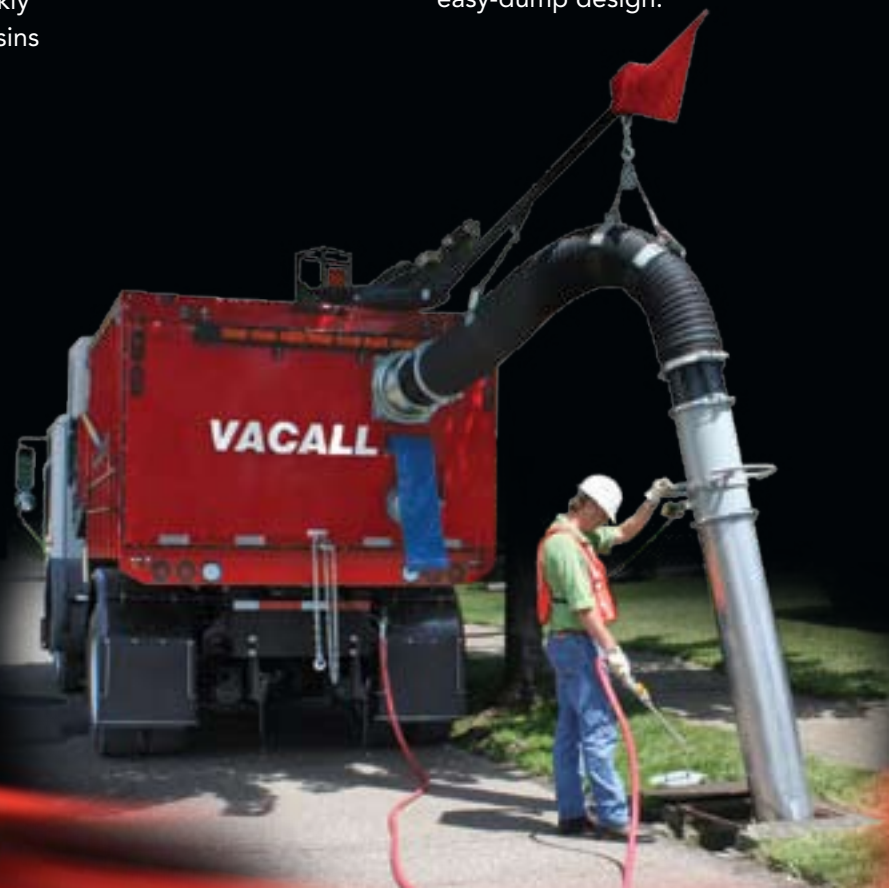



### ► 10 YARD MODEL

10 yard<sup>3</sup> debris tank capacity • heavy gauge construction • 350 gallon UV resistant poly water storage tank • 120 gpm/75 PSI water pump for dust control • 50,000 lb. capacity single cylinder hoist dump system • 33 inch diameter single stage fan capable of 16,500 plus cfm • Auxiliary diesel engine powered

### ► 13 YARD MODEL

13 yard<sup>3</sup> debris tank capacity • less trips to dump, more time sweeping • 350 gallon UV resistant poly water storage tank • 120 gpm/75 PSI water pump for dust control • 50,000 lb. capacity single cylinder hoist dump system • 33 inch diameter single stage fan capable of 16,500 plus cfm • Auxiliary diesel engine powered • More debris storage



### ► 16 YARD MODEL

16 yard<sup>3</sup> debris tank capacity • superb for highway or toll road work • Allows you more time on the job than running to the dump • The largest debris tank surpassed by no other manufacturer in the market • 350 gallon UV resistant poly water storage tank • 120 gpm/75 PSI water pump for dust control • 68,000 lb. capacity twin cylinder hoist dump system • 33 inch diameter single stage fan capable of 16,500 plus cfm • Auxiliary diesel engine powered

All models are offered as a single sweep unit as standard; with the option to upgrade to the dual sweep configuration  
Larger water storage capacity is also available  
Simple to maintain and very versatile

Vacall sweepers are built to last

# VACALL™

Gradall Industries, Inc.  
406 Mill Ave. SW  
New Philadelphia, Ohio 44663  
Phone: 330.339.2211  
Toll Free: 800.382.8302  
Fax: 330.339.8468  
[www.vacallindustries.com](http://www.vacallindustries.com)



Vacall machines are designed and manufactured by Gradall Industries, Inc., a world leader in the production of versatile, reliable maintenance machines. It is our policy to continually improve our products. Therefore, designs, materials and specifications are subject to change without notice and without incurring any liability on units already sold. Units shown may have optional equipment.

Certified ISO 9001 • 12/08  
Form No. 10824 • Printed in U.S.A.